

# **INSTANTANEOUS SAFETY GEAR**

## **ALY05**

### **USER GUIDE**

## **INDEX**

- 1. GENERAL INSTRUCTIONS**
- 2. SAFETY GEAR LABEL AND CHARACTERISATION**
  - 2.1 LABEL
  - 2.2 SAFETY GEAR'S FEATURES AND USE
- 3. INSTALLATION AND ADJUSTMENT**
  - 3.1 ASSEMBLY ON THE FRAME
  - 3.2 SAFETY GEAR ADJUSTMENT
  - 3.3 COUPLING THE DRIVING BAR
- 4. INSPECTION AND MAINTENANCE**
  - 4.1 STORAGE AND SERVICE LIFE
- 5. DIMENSIONS**

# **1 GENERAL INSTRUCTIONS**

ALY05 safety gear meets the requirements of the lift directive 2014/33/EU 81:20 – 81:50.  
Instantaneous safety gear are not regulated. The maximum P+Q depends on the lift tripping speed.

Their features are indelibly shown next to the approval password and serial number on the identification stickers attached to the safety gear

*It is strictly forbidden:*

- a) To combine and assemble safety gear boxes with different serial numbers.
- b) To use a pair of safety gears for installations with characteristics different from those indicated on that pair of safety gears' protection plates.
- c) To handle any of the safety gear's components.

Aksöz Makine San ve Tic Ltd Şti cannot be held responsible for the damage caused due to the non-observance of any of these general instructions.

# **2 SAFETY GEAR LABEL AND CHARACTERISATION**

## **2.1 LABEL**

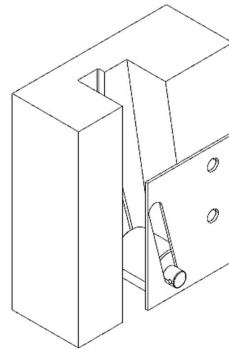

3		<b>AKSÖZ MAKİNA LTD ŞTİ</b>		7
		1187. SOK NO : 8 OSTİM / ANKARA / TURKEY	XXXX	
4		INSTANTANEOUS SAFETY GEAR	CERTIFICATE NO XXXXXXXXXXXX	8
5		RATED SPEED (M/S)	TYPE	9
6		MAX P+Q ( KG )	GUIDE RAILTYPE	10
		GUIDE RAIL	SERIAL NO	

SAFETY GEAR IDENTIFICATION LABEL			
1	Quality assurance CE marking and notified body number	6	Guide rail thickness (mm)
2	Aksöz Makine Ltd Şti address	7	EU type examination certificate number
3	Safety gear type	8	Safety gear type
4	Rated speed / m/s	9	Guide rail type
5	Total max load (P+Q) / kg	10	Serial number

## 2.2 SAFETY GEAR'S FEATURES AND USE

a) Guide rail models to use with this safety:

Type:	T89	T90	T114	T125	T127
Surface	Cold Drawn / machined	Cold Drawn / machined	Cold Drawn / machined	Cold Drawn / machined	Cold Drawn / machined
Guide rail dimensions	89x62x16	90x75x16	114x89x16	125x82x16	127x89x16

\* Allowable tolerances for guide rail thickness should be within the limits set by the standard: ISO 7495:197.

b) The maximum tripping speed for this safety gear is strictly stipulated in the regulation requirements.

	Maximum rated speed (m/s)	Maximum tripping speed (m/s)
Car	0,63	1

## 3 INSTALLATION AND ADJUSTMENT

### 3.1 ASSEMBLY ON THE FRAME

The holes should be made on the frame's uprights to secure the safety gear, according to the dimensions and position displayed in the safety gear drawings attached, ensuring that the guide rail's axis is centred with the frame.

To secure the safety gear onto the frame, we recommend a 79.09 Nm tightening torque for grade 8.8 M12 bolts.

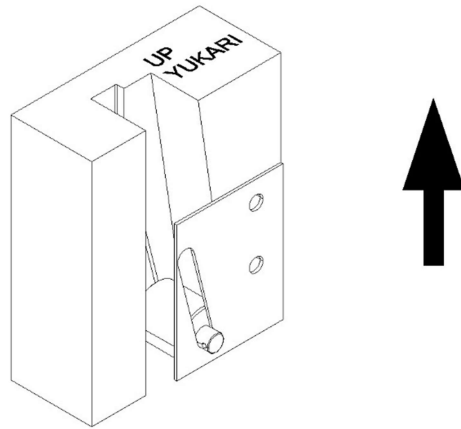
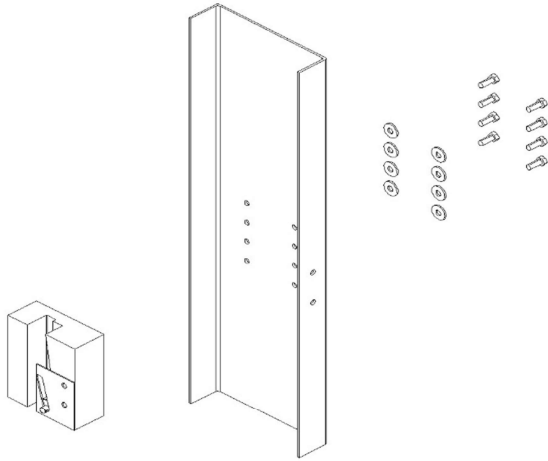

**Direction of assembly**

During assembly, the safety gear should be perfectly aligned with the guide rails, both vertically and horizontally. Improper assembly may cause the safety gear to function incorrectly.

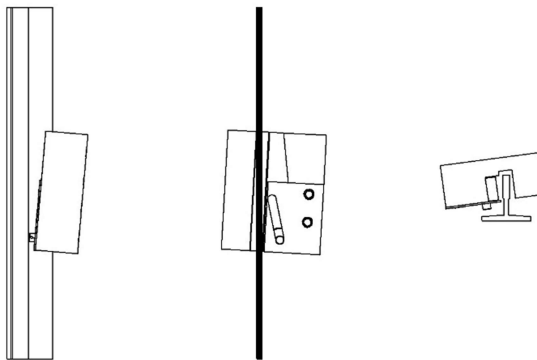

**Improper assembly**

### 3.2 SAFETY GEAR ADJUSTMENT

 In order to avoid problems with the installation's normal operation, it is very important that the person carrying out the installation rigorously observes the distances mentioned in this item.

#### 3.2. THICKNESS GUIDE RAILS

The guide rail's position in the block should be adjusted as follows.

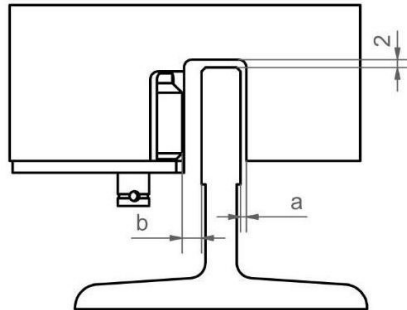

Type:	T89	T90	T114	T125	T127
a	1	1	1	1	1
b	4	4	4	4	4

### 3.3 COUPLING THE DRIVING BAR

It is the responsibility of the person who installs the safety gear to properly position the driving bar in relation to the safety gear, as well as to properly synchronise the safety gears controlled by that driving bar. The correct position is when the safety gear roller is on the bottom of the block.

Once it has been fitted, and the safety gear's rollers have been attached to the driving bar's tripping bars, it should be checked that both rollers operate simultaneously, controlled by the driving bar.

The minimum force required for tripping the safety gear is 300N.

 The Standard demands that the installation incorporate an AC-15 or DC-13 safety contact as defined in EN 60947-5-1.

### 3.3.1 DRIVING BAR

 It is not recommended to exceed a maximum force of 1900 N is not recommended with the governor.

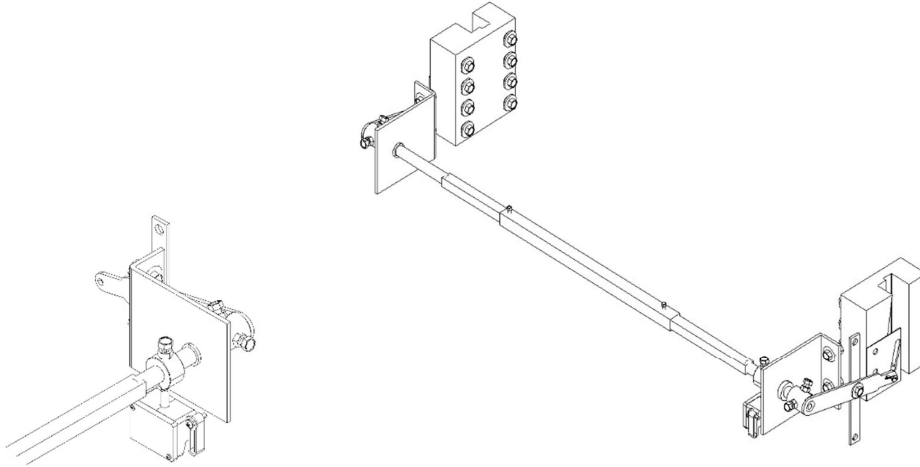

**Safety gear synchronisation bar**

## **4 INSPECTIONS AND MAINTENANCE**

### **4.1 STORAGE AND SERVICE LIFE**

The safety gear should be stored in a cool, dry place. It should be protected from excessive lighting. It should never be exposed to severe weather conditions.

Storage temperature: 5 - 40°C Storage

humidity: 15 - 85% without condensation.

The safety gears' packaging should be clean and dry, so that they can be clearly identified.

It is not permitted to place constant or unbalanced loads on a package, which may cause the package to be bent, or to allow products to be stacked one on top of the other. When stacking products or packages, the storage height should take into account their load and stability.

If the criteria established for proper maintenance are observed, the safety gears may have the same service life as the rest of the installation's fixed elements provided that their proper functioning is ensured and controlled. The element's service life is not affected by grease, dust or dirt due to the shaft's condition or to environmental conditions differing from those stated in this manual.

# 5 DIMENSIONS

