

KABİN KİLİTLEME APARATI | LOCKING PART OF CAR FRAME

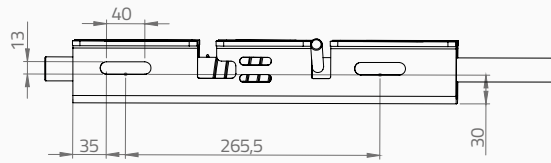
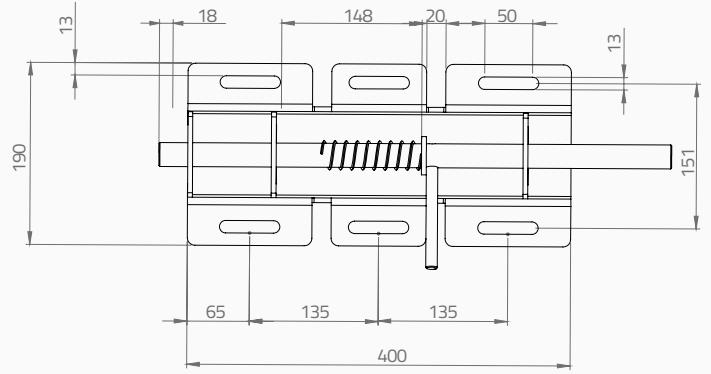
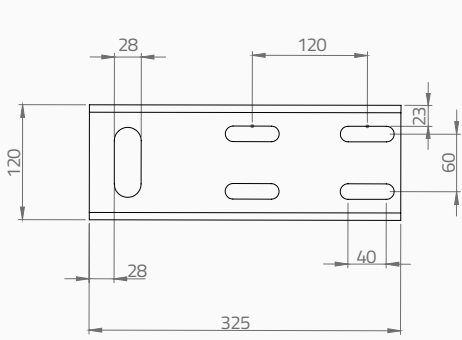

ÜRÜN KODU PRODUCT CODE	MAX TAŞIMA KAPASİTESİ MAX LOAD CAPACITY (kg)	UYUMLU BAĞLANTI VİDASI COMPATIBLE CONNECTION BOLT	AĞIRLIK WEIGHT (kg)
16100		M12 (6 ad/pcs)	9,50

KABİN ASKIYA ALDIKTAN SONRA, İLAVE EMNİYET TERTİBATIDIR. KABİN ASKIYA ALINDIĞINDA, KABİN İÇİNDE İNSAN VE YÜK OLMAMALIDIR.
IT WORKS AS AN ADDITIONAL SAFETY MECHANISM WHEN THE CAR SUSPENDED. WHEN THE CAR SUSPENDED, IT SHOULD NOT BE ANY PERSON OR LOAD INSIDE THE CAR.

TÜM METAL YÜZEYLER GALVANİZLİDİR.
ALL METAL SURFACES ARE GALVANIZED.